

MOOG

G77X/77X Series Installation and Operation Instruction

Electrohydraulic Servovalve

1. INTRODUCTION

This manual provides instructions and procedures necessary to install, operate and troubleshoot the Moog Inc. Series G771/G772/G773 (simplified as G77X) and 771/772/773 (simplified as 77X) Electrohydraulic Industrial Servovalve. Troubleshooting instructions are outlined to permit the identification of the specific component(s) suspected of failure.

2. OPERATION

The Moog G77X/77X Series Industrial Servovalve consists of a polarized electrical torque motor and two stages of hydraulic power amplification. The motor armature extends into the air gaps of the magnetic flux circuit and is supported in this position by a flexure tube member. The flexure tube acts as a seal between the electromagnetic and hydraulic sections of the valve. The two motor coils surround the armature, one on each side of the flexure tube.



The flapper of the first stage hydraulic amplifier is rigidly attached to the midpoint of the armature. The flapper extends through the flexure tube and passes between two nozzles, creating two variable orifices between the nozzle tips and the flapper. The pressure controlled by the flapper and nozzle variable orifice is fed to the end areas of the second stage spool.

The second stage is a conventional four-way spool design in which output flow from the valve, at a fixed valve pressure drop, is proportional to spool displacement from the null position. A cantilever feedback spring is fixed to the flapper and engages a slot at the center of the spool. Displacement of the spool deflects the feedback spring which creates a force on the armature/flapper assembly.

Input signal induces a magnetic charge in the armature and causes a deflection of the armature and flapper. This assembly pivots about the flexure tube and increases the size of one nozzle orifice and decreases the size of the other.

This action creates a differential pressure from one end of the spool to the other and results in spool displacement. The spool displacement transmits a force to the feedback wire which opposes the original input signal torque. Spool movement continues until the feedback wire force equals the input signal force.

ELECTROHYDRAULIC VALVE CUT-AWAY

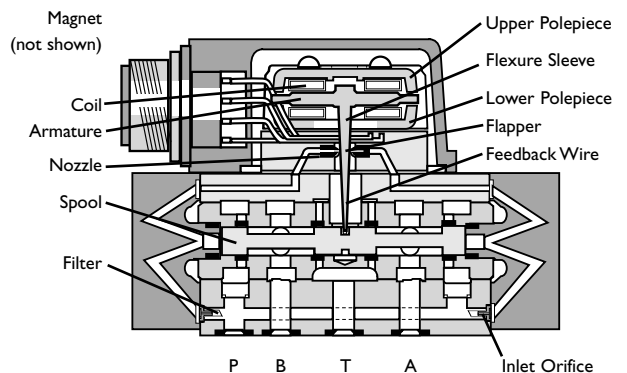

CAUTION

DISASSEMBLY, MAINTENANCE, OR REPAIR OTHER THAN IN ACCORDANCE WITH THE INSTRUCTIONS HEREIN OR OTHER SPECIFIC WRITTEN DIRECTIONS FROM MOOG WILL INVALIDATE MOOG'S OBLIGATIONS UNDER ITS WARRANTY.

Figure 1 Moog Series G77X/77X

3. HYDRAULIC SYSTEM PREPARATION

To prolong servovalve operational life and to reduce hydraulic system maintenance, it is recommended that the hydraulic fluid be kept at a cleanliness level of ISO DIS 4406 Code 16/13 maximum, 14/11 recommended. The most effective filtration scheme incorporates the use of a kidney loop or "off-line" filtration as one of the major filtration components. The filter for the "off-line" filtration scheme should be a $\beta_3 \geq 75$ filter for maximum effectiveness.

Upon system startup and prior to mounting the servovalve, the entire hydraulic system should be purged of built-in contaminating particles by an adequate flushing. The servovalve should be replaced by a flushing manifold and the hydraulic circuit powered up under conditions of fluid temperature and fluid velocity, reasonably simulating normal operating conditions. New system filters are installed during the flushing process whenever the pressure drop across the filter element becomes excessive. The flushing processes should turn over the fluid in the reservoir between fifty to one hundred times.

To maintain a clean hydraulic system, the filters must be replaced on a periodic basis. It is best to monitor the pressure drop across the filter assembly and replace the filter element when the pressure drop becomes excessive. In addition to other filters that are installed in the hydraulic circuit, it is recommended that a large capacity, low pressure $\beta_3 \geq 75$ filter be installed in the return line. This filter will increase the interval between filter element replacements and greatly reduce the system contamination level.

4. INSTALLATION

The Moog G77X/77X Series Industrial Servovalve may be mounted in any position, provided the servovalve pressure, piston and return ports match respective manifold ports.

The mounting pattern, port location and mounting bolts of the servovalve are shown on Figure 4. Apply a light film of oil to the screw threads and torque to 57 inch-pounds.

Wire mating connector for desired coil configuration and polarity. Thread connector to valve.

5. MECHANICAL NULL ADJUSTMENT

It is often desirable to adjust the flow null of a servovalve independent of other system parameters. The "mechanical null adjustment" on the Moog G77X/77X Series servovalve allows at least $\pm 20\%$ adjustment of flow null. The "mechanical null adjustor" is an eccentric bushing retainer pin located above the port designation on the valve body (see Figure 2) which, when rotated, provides control of the bushing position. Mechanical feedback elements position the spool relative to the valve body for a given input signal. Therefore, a movement of the bushing relative to the body changes the flow null.

Adjustment Procedure

1. Using a $\frac{3}{32}$ inch Allen wrench, rotate mechanical null adjustor pin to obtain desired flow null. If excessive torque (more than 12 in.-lb.) is required to rotate null adjustor pin, perform Step 2.

Note:

Clockwise rotation of null adjustor pin produces open loop flow from port B to port A.

2. Using a $\frac{3}{8}$ inch offset box wrench, loosen self-locking fitting. DO NOT remove self-locking fitting. Insert a $\frac{3}{32}$ inch Allen wrench in null adjustor pin. Using the $\frac{3}{8}$ inch offset box wrench, tighten self-locking fitting until a torque of 10 to 12 in.-lb. is required to rotate null adjustor pin with the Allen wrench. Perform Step 1 to establish desired flow null.

Table I. Replacement Parts

Part Description	Qty.	Part Number
G77X/77X Series Filter Replacement Kit	1	B52555RK54K1
Inlet Orifice End Cap O-Rings (1)	2	42082-1
Inlet Orifice O-Rings (1)	2	42082-189
End Cap - Bushing O-Rings (1)	2	42082-42
Filter Tube (1)	1	C39486-5-60
End Cap - O-Rings (1)	2	42082-1
Base O-Rings		
G771/771	4	42082-7
G772/772	4	42082-13
G773/773	4	42082-22

(1) Included in Filter Replacement Kit.

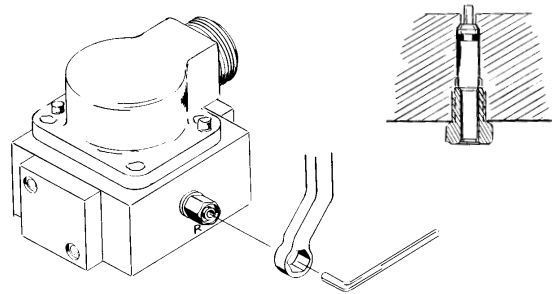

Figure 2
Mechanical Null Adjustment

6. GENERAL SERVICING RECOMMENDATIONS

- a. Disconnect electrical lead to servovalve.
- b. Relieve hydraulic system of residual pressure.
- c. Remove servovalve.

7. TROUBLESHOOTING CHART

The following troubleshooting chart lists potential troubles encountered, probable causes, and remedies.

Potential Trouble	Probable Cause	Remedy
Servovalve does not follow input command signal. (Actuator or components are stationary or creeping slowly.)	Plugged inlet filter element.	Replace filter element.
High threshold. (Jerky, possible oscillatory or "hunting" motion in closed loop system.)	Plugged filter element.	Replace filter element.
Poor response. (Servovalve output lags electrical command signal).	Partially plugged filter element.	Replace filter element and check for dirty hydraulic fluid in system.
High Null Bias. (High input current required to maintain hydraulic cylinder or motor stationary.)	1. Incorrect null adjustment 2. Partially plugged filter element.	1. Readjust null 2. Replace filter element and check for dirty hydraulic fluid in system.



Tools and Equipment

- Blade screwdriver
- $\frac{3}{16}$ Allen wrench
- No. 2-56 NC by $1\frac{1}{2}$ inch screw
- Torque wrenches

8. FILTER ASSEMBLY REPLACEMENT

- Remove four socket head cap screws and lockwashers using a $\frac{3}{16}$ inch Allen wrench. Remove end caps. (See Figure 3).
- Remove O-Rings from end caps.
- Remove inlet orifice assembly from both sides of body.
Note: 2-56 screw threads into the filter plug and inlet orifice assembly. Remove filter: The inlet orifice assemblies are matched to each other and are therefore interchangeable.
Note: These assemblies seat in body and cannot go through bore during removal.
- Remove O-Rings from inlet orifice assemblies.
- Visually inspect orifice assemblies for damage or foreign material.
- Discard O-Rings and filters.
- Install O-Rings on inlet orifices.
- Install filter and inlet orifice assembly in body. Inlet orifice assembly pilots into filter. Install the other inlet orifice assembly into other end of filter. Inlet orifice assemblies are interchangeable.
- Install O-Rings on end caps.
- Install end caps on body and install four socket head cap screws and lockwashers. Torque the screws to 85 inch-pounds.

9. FUNCTIONAL CHECKOUT AND CENTERING

- Install servovalve on hydraulic system or test fixture, but do not connect electrical lead.
- Apply required system pressure to servovalve and visually examine for evidence of external leakage. If leakage is present and cannot be rectified by replacing O-Rings, remove the discrepant component and return for repair or replacement.
Note: If the system components are drifting or hardover, adjust the mechanical null of the servovalve.
- Connect electrical lead to servovalve and check phasing in accordance with system requirements.

10. AUTHORIZED REPAIR FACILITIES

If servovalve continues to malfunction after all recommended corrective action procedures are performed, defective valve should be returned to Moog for repair. Moog does not authorize any facilities other than Moog or Moog subsidiaries to repair its servovalves. It is recommended you contact Moog at (716)655-3000 to locate your closest Moog repair facility. Repair by an independent (unauthorized) repair house will result in voiding the Moog warranty and could lead to performance degradation or safety problems.

G77X/77X SERIES INSTALLATION AND OPERATION INSTRUCTION

NOTES

1 Fluid:

Industrial type petroleum base hydraulic fluid, maintained to ISO DIS 4406 Code 14/11 recommended.

2 Operating Temperature Range:

-20°F [-29°C] to +275°F [+135°C]

3 Valve Phasing:

Flow out port B results when Series coils: B & C connected, A+, D-; Parallel coils: A & C connected, B & D connected; Single coil: A+, B-, or C+, D-.

4 Ports:

See table below left.

5 Surface:

Surface to which valve is mounted requires $\sqrt{32}$ [TIR] finish, flat within 0.002 [0.05] TIR.

6 Null Adjust:

Flow out port B results with clockwise rotation of null adjust screw ($\frac{3}{32}$ hex key). Flow bias is continually varied for a given port as the null adjust is rotated.

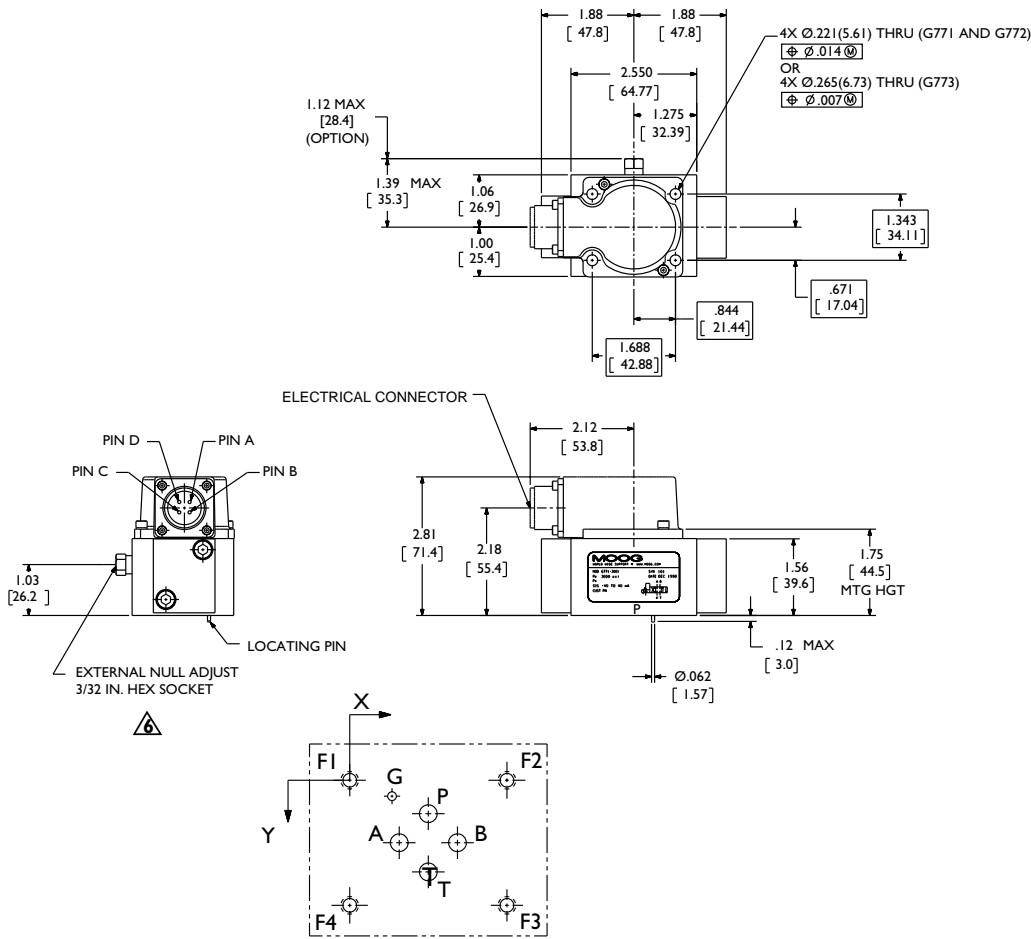

TYPICAL WIRING SCHEMATIC

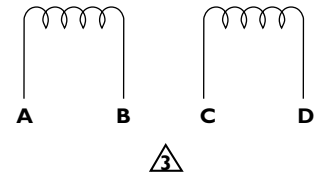

G771/771 U.S.

	P	A	B	T	G	F1	F2	F3	F4
	Ø .191	Ø .191	Ø .191	Ø .191	Ø .094	.190-32	.190-32	.190-32	.190-32
X	0.84	0.53	1.16	0.84	0.45	0	1.69	1.69	0
Y	0.36	0.67	0.67	0.98	0.17	0	0	1.34	1.34

METRIC

	P	A	B	T	G	F1	F2	F3	F4
	4.85	4.85	4.85	4.85	2.39	M5	M5	M5	M5
X	21.3	13.5	29.5	21.3	11.4	0	42.9	42.9	0
Y	9.1	17.0	17.0	24.9	4.3	0	0	34.0	34.0

G772/772 U.S.

	P	A	B	T	G	F1	F2	F3	F4
	Ø .260	Ø .260	Ø .260	Ø .260	Ø .094	.190-32	.190-32	.190-32	.190-32
X	0.84	0.45	1.23	0.84	0.45	0	1.69	1.69	0
Y	0.28	0.67	0.67	1.06	0.17	0	0	1.34	1.34

METRIC

	P	A	B	T	G	F1	F2	F3	F4
	6.6	6.6	6.6	6.6	2.39	M5	M5	M5	M5
X	21.3	11.4	31.2	21.3	11.4	0	42.9	42.9	0
Y	7.2	17.0	17.0	27.0	4.3	0	0	34.0	34.0

G773/773 U.S.

	P	A	B	T	G	F1	F2	F3	F4
	Ø .312	Ø .312	Ø .312	Ø .312	Ø .094	.250-20	.250-20	.250-20	.250-20
X	0.84	0.38	1.31	0.84	0.45	0	1.69	1.69	0
Y	0.20	0.67	0.67	1.14	0.17	0	0	1.34	1.34

METRIC

	P	A	B	T	G	F1	F2	F3	F4
	7.92	7.92	7.92	7.92	2.39	M6	M6	M6	M6
X	21.3	9.7	33.3	21.3	11.4	0	42.9	42.9	0
Y	5.1	17.0	17.0	29.0	4.3	0	0	34.0	34.0

Figure 4

Three standard designs are available.

Model Number	Port Circle Diameter in	Port Circle Diameter mm	Port Diameter in	Port Diameter mm	Manifold O-Rings Moog	Manifold O-Rings MS	Mounting Bolt Size (socket head cap screws)
G771/771	.625	15.8	.191	4.85	-007	-010	.190-32 NF x 2.0 long
G772/772	.780	19.8	.260	6.60	-013	-012	.190-32 NF x 2.0 long
G773/773	.937	23.8	.312	7.93	-022	-013	.250-20 NF x 2.25 long

MOOG

Industrial Controls Division
 Moog Inc., East Aurora, NY 14052-0018
 Telephone: 716/655-3000
 Fax: 716/655-1803
 Toll Free: 1-800-272-MOOG
 www.moog.com